

## 8 Channel RF transmitter

For use with Velleman K8056 relay card, 8 addresses allow the use of multiple receivers in one room.

Total solder points: 63

Difficulty level: *beginner* 1  2  3  4  5  *advanced*



# K8058

### Features:

- ☑ Works together with the K8056 relay card.
- ☑ 8 addresses allow the use of multiple receivers.
- ☑ 'all clear'- function.
- ☑ Toggle or momentary mode for each key.
- ☑ Open-field range up to 50m.
- ☑ Rubber keypad.

### Specifications:

- 433MHz operation
- LED function/mode indication
- Power supply: 3 AAA batteries (not included).
- Dimensions: 150 x 58 x 20mm (5.9" x 2.3" x 0.8")

### Schematic diagram.

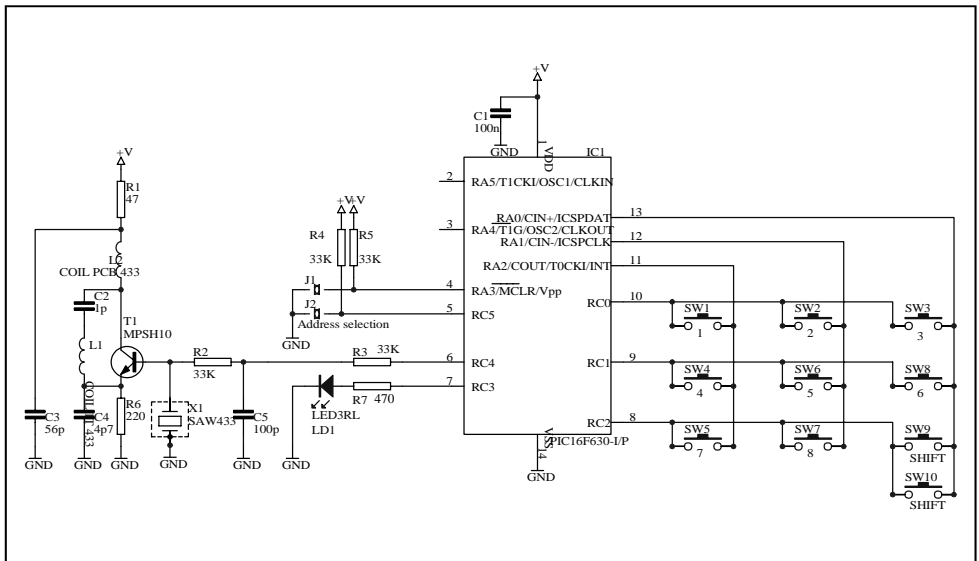

**1. Assembly (Skipping this can lead to troubles !)**

Ok, so we have your attention. These hints will help you to make this project successful. Read them carefully.

**1.1 Make sure you have the right tools:**

- A good quality soldering iron (25-40W) with a small tip.
- Wipe it often on a wet sponge or cloth, to keep it clean; then apply solder to the tip, to give it a wet look. This is called 'thinning' and will protect the tip, and enables you to make good connections. When solder rolls off the tip, it needs cleaning.
- Thin raisin-core solder. Do not use any flux or grease.
- A diagonal cutter to trim excess wires. To avoid injury when cutting excess leads, hold the lead so they cannot fly towards the eyes.
- Needle nose pliers, for bending leads, or to hold components in place.
- Small blade and Phillips screwdrivers. A basic range is fine.

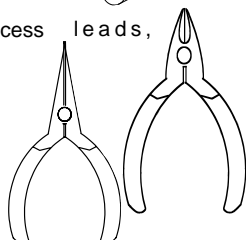
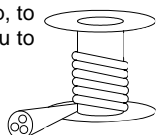
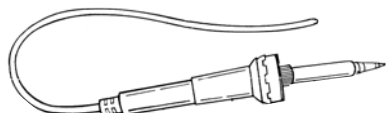

**For some projects, a basic multi-meter is required, or might be handy**

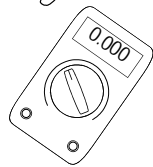

**1.2 Assembly Hints :**

- ⇒ Make sure the skill level matches your experience, to avoid disappointments.
- ⇒ Follow the instructions carefully. Read and understand the entire step before you perform each operation.
- ⇒ Perform the assembly in the correct order as stated in this manual
- ⇒ Position all parts on the PCB (Printed Circuit Board) as shown on the drawings.
- ⇒ Values on the circuit diagram are subject to changes.
- ⇒ Values in this assembly guide are correct\*
- ⇒ Use the check-boxes to mark your progress.
- ⇒ Please read the included information on safety and customer service
  
- ⇒ \* Typographical inaccuracies excluded. Always look for possible last minute manual updates, indicated as 'NOTE' on a separate leaflet.

### 1.3 Soldering Hints :

1- Mount the component against the PCB surface and carefully solder the leads

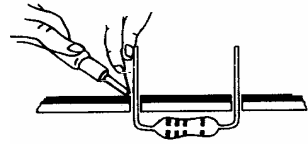

2- Make sure the solder joints are cone-shaped and shiny

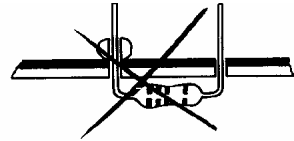
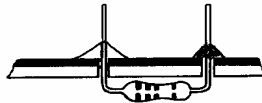

3- Trim excess leads as close as possible to the solder joint

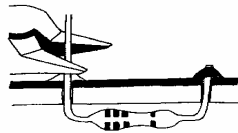

REMOVE THEM FROM THE TAPE ONE AT A TIME !

**AXIAL COMPONENTS ARE TAPED IN THE CORRECT MOUNTING SEQUENCE !**

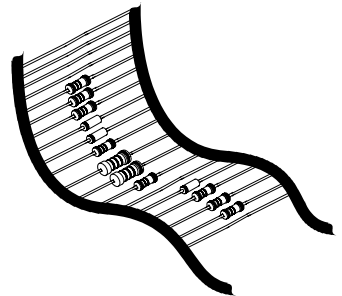

Velleman hereby certifies that the device K8058 meets the essential requirements and all other relevant stipulations of directive 1999/5/EG and 1995/5/EC.

For the complete conformity declaration check out :[http://www.velleman.be/downloads/doC/CE\\_K8058.pdf](http://www.velleman.be/downloads/doC/CE_K8058.pdf)

### 1. Jumpers

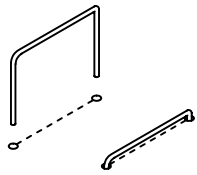

- J1
- J2
- J3
- J4
- J5
- J6

### 2. 1/8W Resistors

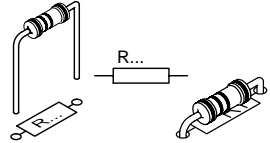

- R1 : 47 (4-7-0-B)
- R2 : 33K (3-3-3-B)
- R3 : 33K (3-3-3-B)
- R4 : 33K (3-3-3-B)
- R5 : 33K (3-3-3-B)
- R6 : 220 (2-2-1-B)
- R7 : 470 (4-7-1-B)

### 3. SAW resonator.

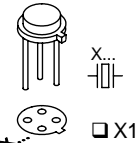

**CHECK THE POSITION OF THE NOTCH!**

- X1 : SAW433

### 4. Ceramic Capacitors

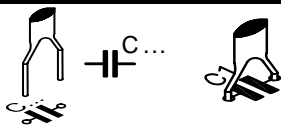

- C1 : 100nF (104,  $\mu$ 1)
- C2 : 1pF (Red, purple)
- C4 : 4,7pF (Black)
- C3 : 56pF (56)
- C5 : 100pF (101)

### 5. IC socket. Watch the position of the notch!

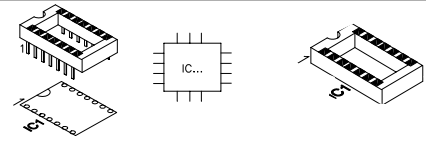

- IC1 : 14p

### 6. Coil

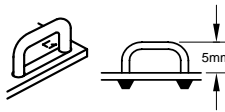

A simple air core coil has to be made as shown in the diagram using the jumper lead supplied

- L1 : 1 turn

### 7. Transistor

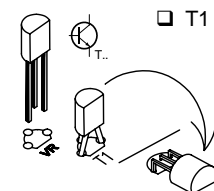

- T1 : MPSH10

### 8. LED. Watch the polarity!

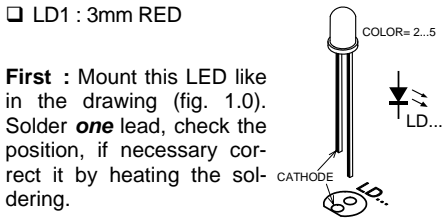

- LD1 : 3mm RED

**First :** Mount this LED like in the drawing (fig. 1.0). Solder **one** lead, check the position, if necessary correct it by heating the soldering.

**Next :** solder the second connection.

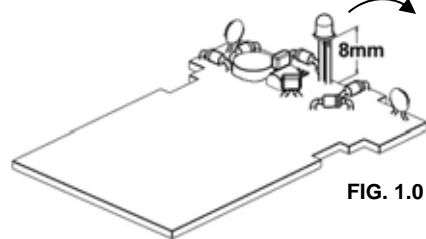
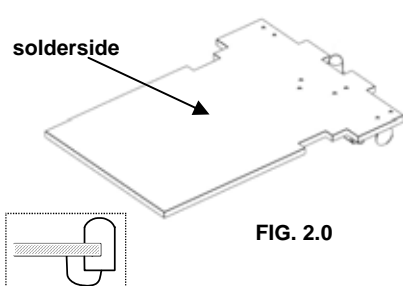

FIG. 1.0

**Last :** Bend the LED exactly like the drawing (fig. 2.0).



solderside

FIG. 2.0

**9. IC. Watch the position of the notch!**

- ❑ IC1 : VK8058 programmed Pic16F630.

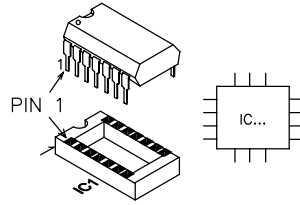

**10. Battery contacts**

- ❑ Solder a wire of 8cm (Ø 0,20mm) to the negative (-) connection of the PCB. The other end of the wire will be soldered to the negative battery contact later on.

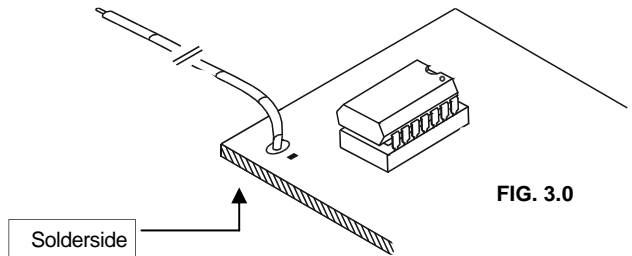

FIG. 3.0

- ❑ Now place the battery contacts into the housing on their right places.

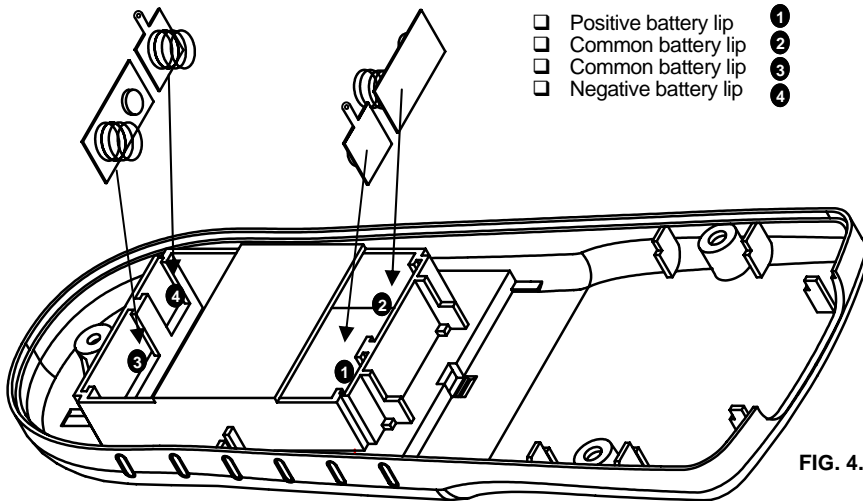
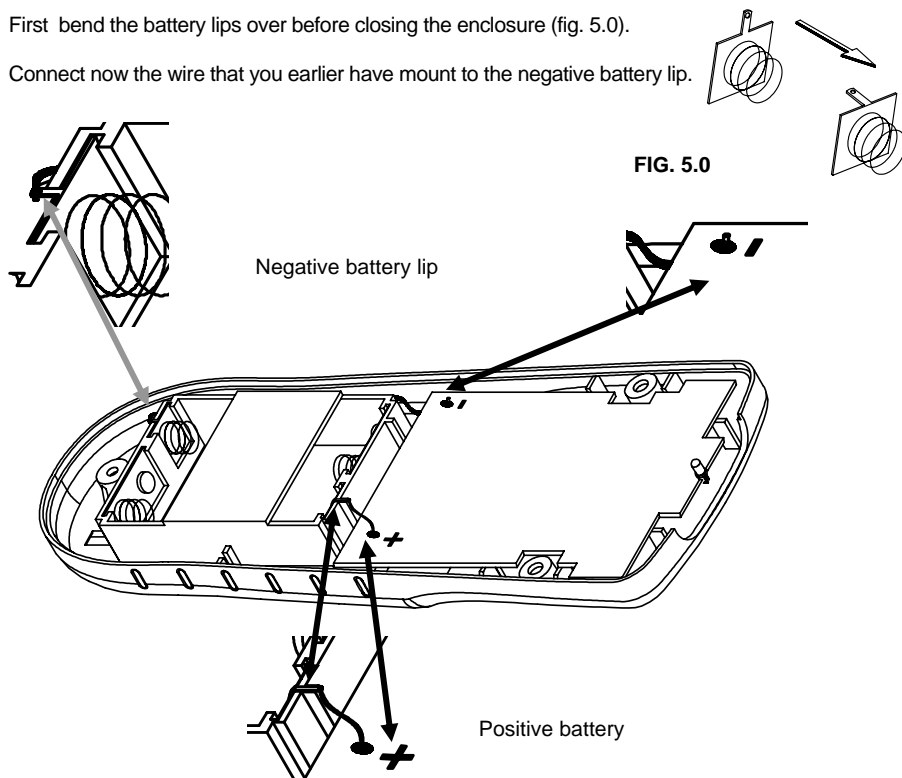

FIG. 4.0

- ❑ First bend the battery lips over before closing the enclosure (fig. 5.0).
- ❑ Connect now the wire that you earlier have mount to the negative battery lip.



- ❑ Connect a wire between the positive battery lip and positive connection on the pcb.

### 11. Sticker

Affix the supplied sticker to the backside of the housing, see fig 6.0

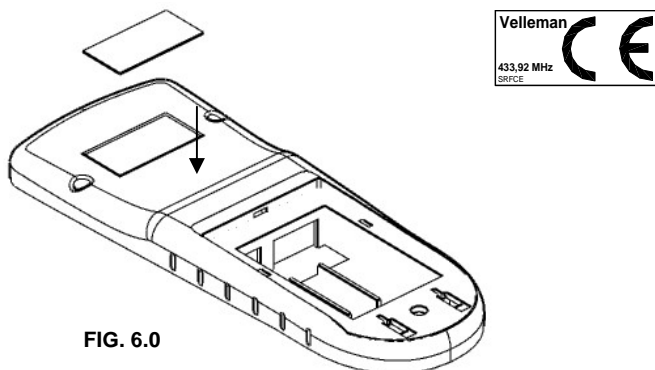

## 12. Assembly

- ❑ Close the enclosure with the supplied screws.

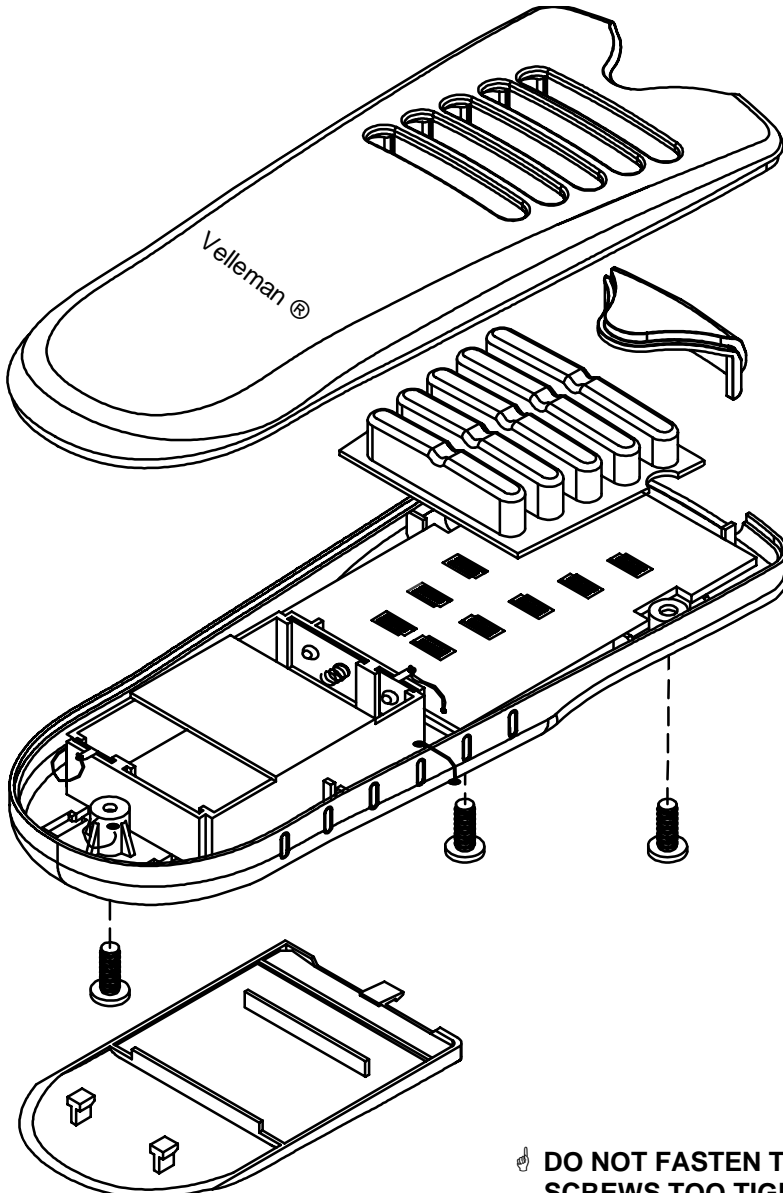



### 13. Keyboard Layout

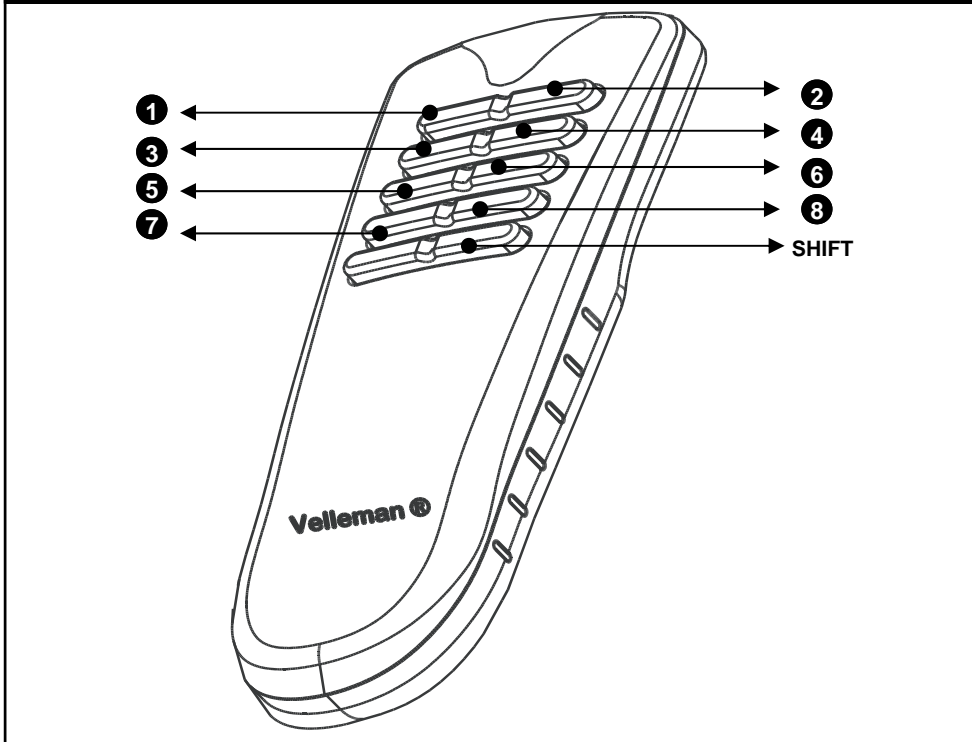

### 14. Use

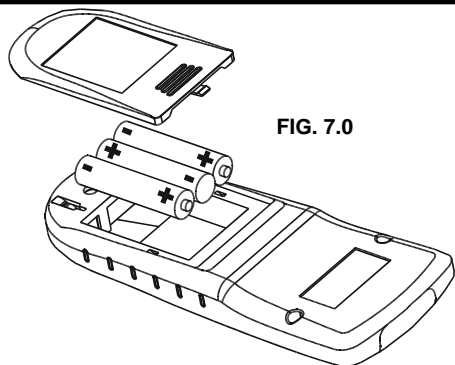

Insert the batteries in the battery compartment as indicated in fig. 8.0 and close the compartment.



**Remark :** Respect your national and local laws when disposing of empty batteries.

**When the batteries are inserted for the first time :**

Channels 1..8 are configured as 'toggle' and are accessible by pressing button 1..8.

The indicator led will briefly light when a button is pressed.

Briefly pressing the shift button turns off all relays.

8 Addresses are available. Address 1 is the default address.

**When the batteries are replaced :**

The unit will remember its address and the 'toggle/'momentary' setting for each channel.

## 15. Setup

Hold 'shift' until the LED lights to enter the 'set-up' mode.

Choose one of the following options by pressing the corresponding button :

- (1) 'Toggle'/'pulse'-selection.
- (2) Display the current remote control address
- (3) Change remote/relay card address
- (4) Force remote/relay card address to address 1

### **(1) 'Toggle'/'pulse'-selection (LED flashes once) :**

Allows you to select 'toggle' or 'pulse' mode for each channel.

Pressing a channel button (1..8) repeatedly allows you to choose between 'toggle'- and 'pulse'-mode for that particular channel (LED flashes once : pulse, two flashes : toggle).

Press 'shift' to leave this mode. Press 'shift' again to leave set-up mode.

### **(2) Display the current remote control address on the K8056 relay card (LED flashes twice) :**

Relay LEDs display the address in binary fashion i.e. LD8 : LSB, LD1 : MSB

Press 'shift' to leave the set-up mode.

### **(3) Change the current address of the remote and relay card (available addresses : 1..8) (LED flashes three times) :**

Press button 1..8 to change the current address of the remote and the relay card.

The relay card will display the current address in binary fashion (see (2)).

**Attention :** All active cards will respond to this command (except when the 'remote control' jumper on the relay card is set to 'off'). Press 'shift' to leave this mode. Press 'shift' again to leave the set-up mode.

### **4) Force the remote/relay card to address 1.**

If the receiver (e.g. K8056) has been set to an address other than 1..8, you can force it to respond to address 1.

 **Attention :** All active cards will respond to this command (except when the 'remote control' jumper on the relay card is set to 'off'). Press 'shift' to leave the set-up mode.

You can leave the 'set-up' mode at any given time by pressing the 'shift'-button repeatedly until the LED turns off. If no button is pushed for a while, the unit will leave the 'setup'-mode and the LED will turn off.

15. PCB layout.

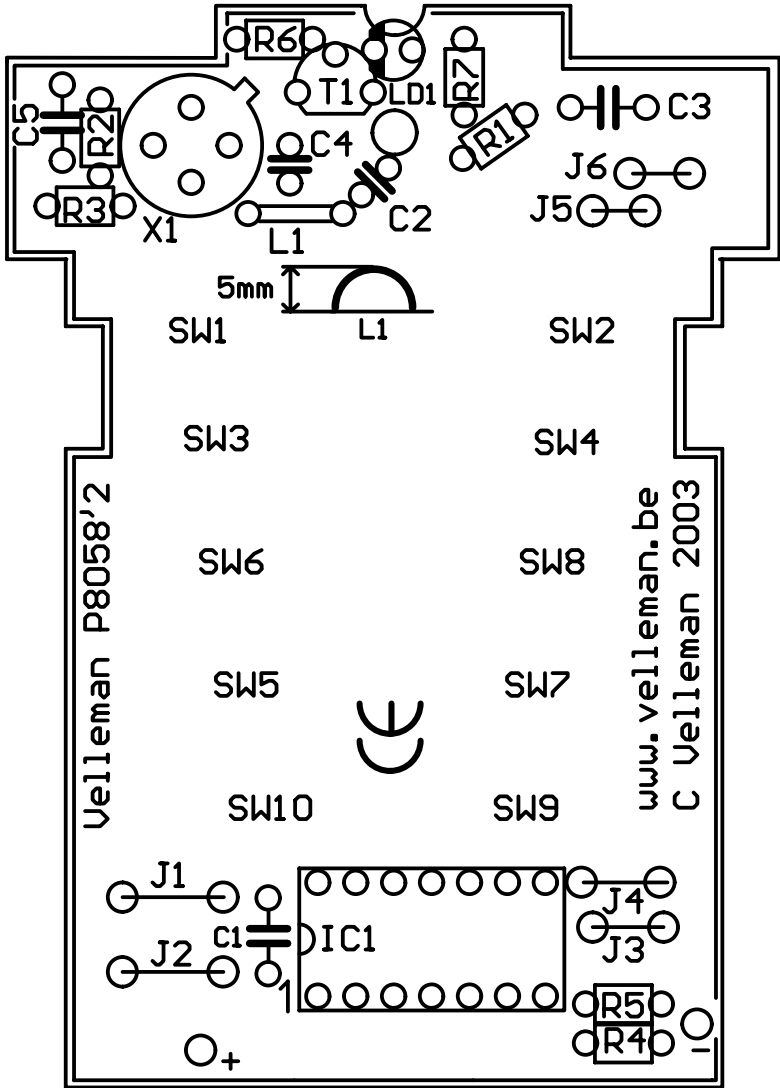



**VELLEMAN KIT NV**  
**Legen Heirweg 33**  
**9890 Gavere**  
**Belgium Europe**  
**Info ? : <http://www.velleman.be>**

Modifications and typographical errors reserved  
© Velleman Kit nv  
H8058IP - 2004 - ED1

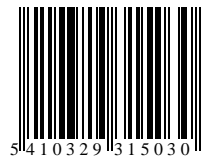

5410329315030