

Total solder points: 113

Difficulty level: *beginner* 1 2 3 4 5 *advanced*

DUAL FUNCTION STROBE



K5203

Create fantastic light effects for
disco, photographs, signalisation, ...

Specifications:

- Create fantastic light effects for disco, photographs, signalisation..
- Two operating modes:
 - Flashes on power down.
 - For use in combination with light computer K5201, running lights K5200, K8032 or other light effect generator.
 - Continuous flashing with adjustable speed.
- Simple two-wire connection.
- High power flash tube.
- Power on LED.
- Reflector included.

Features:

- Power supply : 230VAC / 50 Hz
- Power consumption : 20W max. / 3W standby
- Max flash rate : 20 flashes/s
- Dimensions (W x L x H): 70 x 120 x 50 mm

1. Assembly (Skipping this can lead to troubles !)

Ok, so we have your attention. These hints will help you to make this project successful. Read them carefully.

1.1 Make sure you have the right tools:

- A good quality soldering iron (25-40W) with a small tip.
- Wipe it often on a wet sponge or cloth, to keep it clean; then apply solder to the tip, to give it a wet look. This is called 'thinning' and will protect the tip, and enables you to make good connections. When solder rolls off the tip, it needs cleaning.
- Thin raisin-core solder. Do not use any flux or grease.
- A diagonal cutter to trim excess wires. To avoid injury when cutting excess leads, hold the lead so they cannot fly towards the eyes.
- Needle nose pliers, for bending leads, or to hold components in place.
- Small blade and Phillips screwdrivers. A basic range is fine.

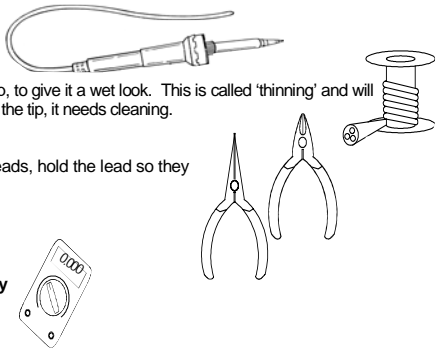

For some projects, a basic multi-meter is required, or might be handy

1.2 Assembly Hints :

- ⇒ Make sure the skill level matches your experience, to avoid disappointments.
 - ⇒ Follow the instructions carefully. Read and understand the entire step before you perform each operation.
 - ⇒ Perform the assembly in the correct order as stated in this manual
 - ⇒ Position all parts on the PCB (Printed Circuit Board) as shown on the drawings.
 - ⇒ Values on the circuit diagram are subject to changes.
 - ⇒ Values in this assembly guide are correct*
 - ⇒ Use the check-boxes to mark your progress.
 - ⇒ Please read the included information on safety and customer service
- * Typographical inaccuracies excluded. Always look for possible last minute manual updates, indicated as 'NOTE' on a separate leaflet.

1.3 Soldering Hints :

1- Mount the component against the PCB surface and carefully solder the leads

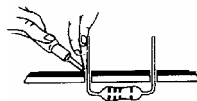

2- Make sure the solder joints are cone-shaped and shiny

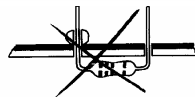
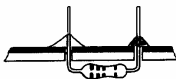

3- Trim excess leads as close as possible to the solder joint

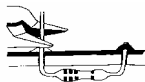

REMOVE THEM FROM THE TAPE ONE AT A TIME !

AXIAL COMPONENTS ARE TAPED IN THE CORRECT MOUNTING SEQUENCE !

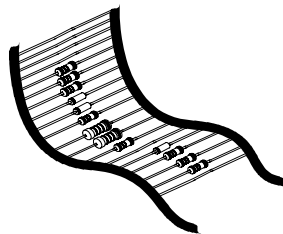

 You will find the colour code for the resistances and the LEDs in the HALG (general manual) and on our website: <http://www.velleman.be/common/service.aspx>

1. Jumpers

- J1
- J2

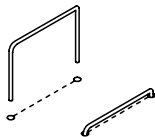

4. Zener diodes. Watch the polarity !

- ZD1 : 15V
- ZD2 : 2V4

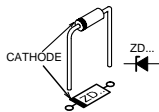

6. 1W Resistors

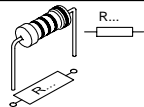

- R12 : 100K (1 - 0 - 4 - B)
- R13 : 100K (1 - 0 - 4 - B)
- R14 : 100K (1 - 0 - 4 - B)
- R15 : 100K (1 - 0 - 4 - B)

2. DIAC

- D1 : D0200YR

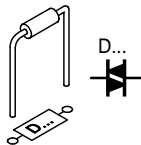

5. Resistors

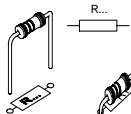

- R1 : 15K (1 - 5 - 3 - B)
- R2 : 10K (1 - 0 - 3 - B)
- R3 : 4K7 (4 - 7 - 2 - B)
- R4 : 100K (1 - 0 - 4 - B)
- R5 : 100K (1 - 0 - 4 - B)
- R6 : 100K (1 - 0 - 4 - B)
- R7 : 100K (1 - 0 - 4 - B)
- R8 : 100K (1 - 0 - 4 - B)
- R9 : 100K (1 - 0 - 4 - B)
- R10 : 100K (1 - 0 - 4 - B)
- R11 : 100K (1 - 0 - 4 - B)

7. Transistor.

- T1 : BC337

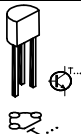

3. Diodes. Watch the polarity !

- D2 : 1N4148
- D3 : 1N4007
- D4 : 1N4007
- D5 : 1N4007
- D6 : 1N4007
- D7 : 1N4007
- D8 : 1N4007

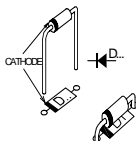

8. Capacitor.

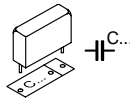

- C1 : 100nF / 400V (104 - μ1)

9. LED. Check the polarity!

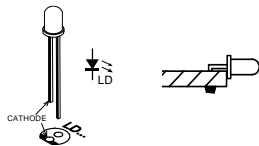

LD1 : 5mm RED

☞ Depending the used housing,
mount the LED horizontal or
vertical.

10. Screw connector

SK1 : 3 P

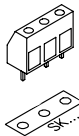

11. Trigger coil

L1 : TC6

☞ Mind the orientation

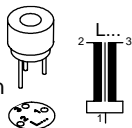

12. Resistor trimmer

RV1 : 1M

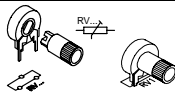

13. Electrolytic Capacitors. Watch the polarity !

C2 : 1 μ F

C3 : 4,7 μ F

C4 : 100 μ F

C5 : 100 μ F

C6 : 100 μ F

C7 : 100 μ F

C8 : 100 μ F

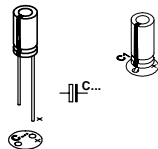

14. Fuse + Holder

F1 : 250mA slow

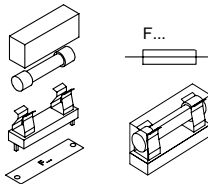

15. Triac.

TR1 : TIC206M or eq.

☞ MIND THE ORIENTATION !

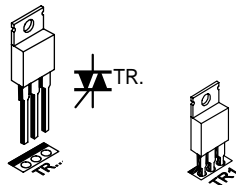

16. Switch.

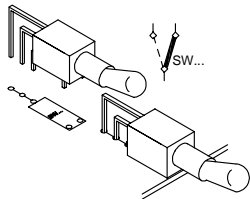

□ SW1: TS8 (ON - ON)

17. 5W resistors.

- R16 : 220
- R17 : 220
- R18 : 220
- R19 : 220

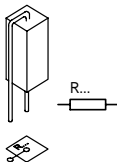

18. Strobe tube. Watch the polarity !

Avoid touching the tube. Eventually, it can be cleaned with a dry cloth. Mind the correct orientation of the tube. Solder the tube in place, parallel to the PCB border, as shown. Connect the loose wire to point **W**.

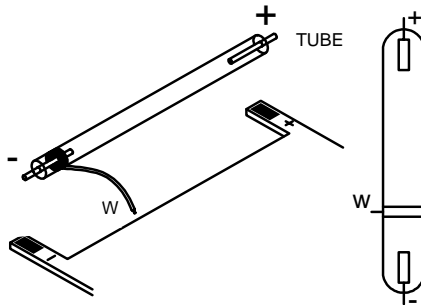

CAUTION: under operating condition, voltages up to 6KV can be present at point **W**.

19. Mounting the reflector behind the tube

Solder the reflector on the PCB as shown. Be sure the shiny side faces the flashtube. For improved efficiency, you can bend it in a parabola shape according to the drawing. Use a round tube of about 38mm, to create a smooth circle

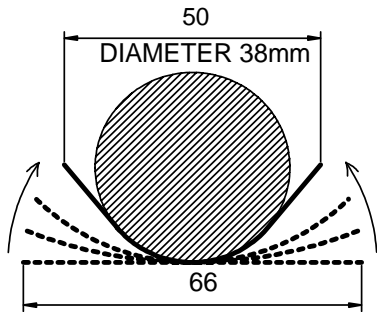

Fig. 2.0

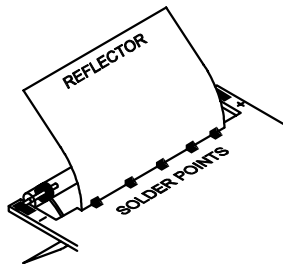

Fig. 3.0

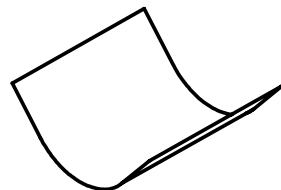

Fig. 1.0

20. Test



WARNING : The circuit is directly connected to the mains and carries a lethal tension ! Make sure that no part of the circuit can be touched during operation. All capacitors must be fully discharged before touching the circuit. The flash tube can reach high temperatures during operation, and can cause burns.

Connect the mains to the connector marked AC mains, the LED should light up.

In one mode, selectable with the switch SW1, the unit should flash when the power is disconnected. In the other mode the unit can flash continuously, the flash rate can be adjusted by means of RV1.

21. Building into an enclosure

 **It is recommended to mount the unit into an enclosure (due to high voltages).**

Provide sufficient airflow by drilling some 4mm ventilation holes in the cabinet. Use a cable exit grommet for the AC cord. For safety, we recommend you close the flash-tube side of the box with a glass or plexi window. If a metal enclosure is used, be sure to earth all the metal parts and to leave a minimum space of 5mm between the enclosure and any live part. Two fixation holes are already connected to earth on the PCB as are the metal parts like the reflector and the switch.

22. Connection examples

As the circuit requires only two wires, a manual remote control can easily be made by means of a push-button switch (NC contact, 230 V compatible, fig.4.0).

Of course you can use any other control circuit which is able to switch the mains ON and OFF. Use a wire diameter of a least 0.75 mm² for all interconnections and be sure to isolate all live parts.

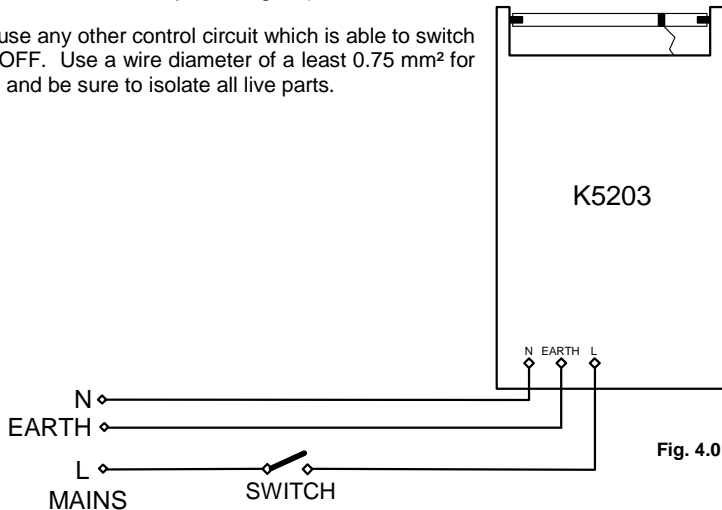

Fig. 4.0

Automatic control with our four channel multifunction runninglight (K5200) :

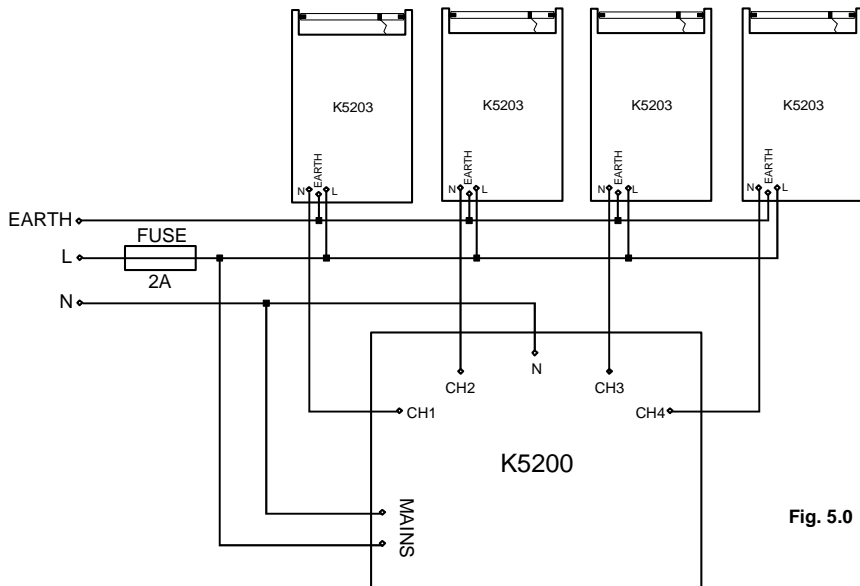

Fig. 5.0

Automatic control with our four channel multifunction runninglight (K8032) :

Fig. 6.0

Automatic control with our lightcomputer (K5201) :

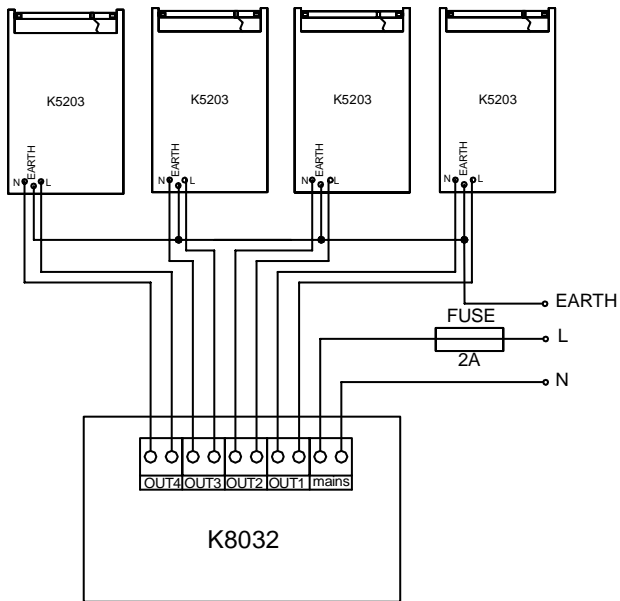
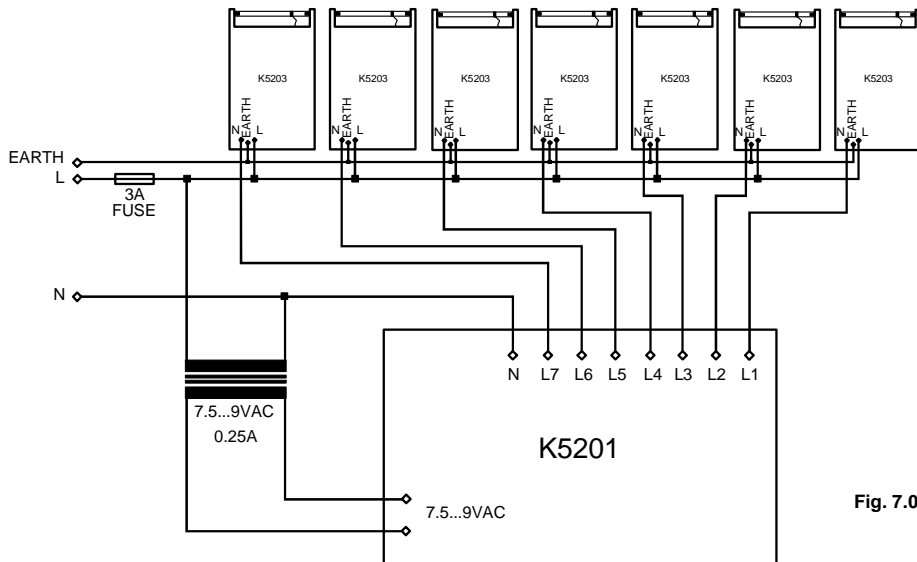
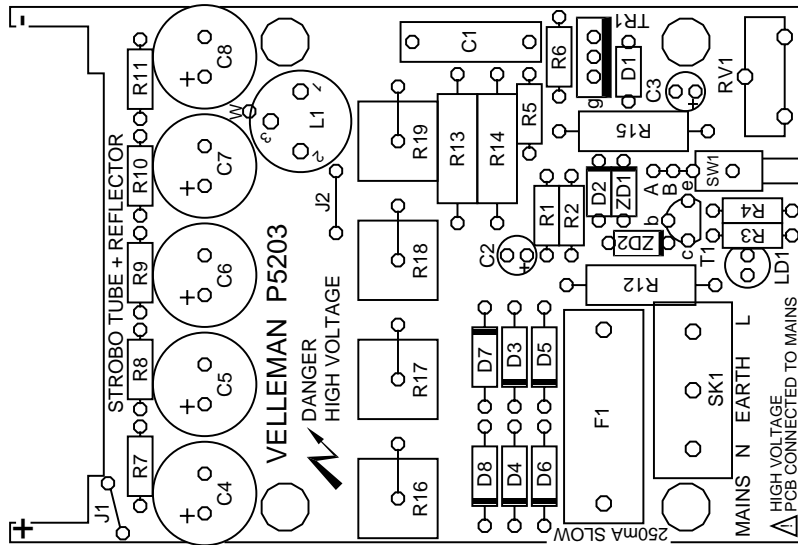
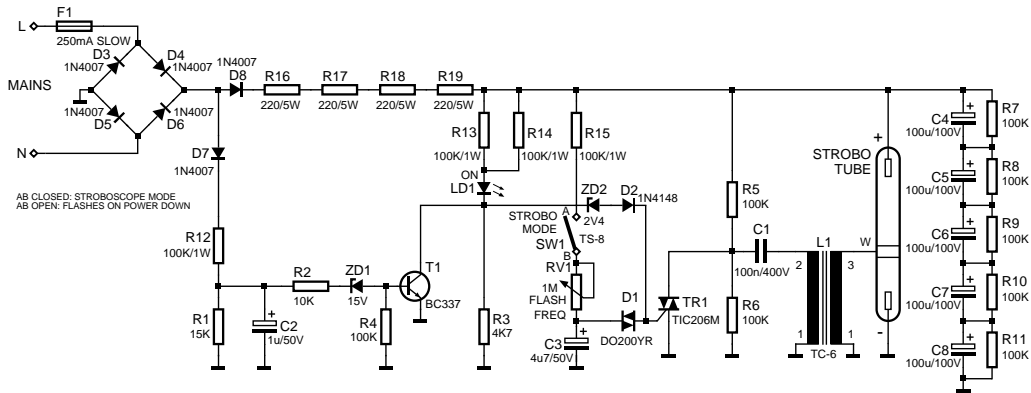

Fig. 7.0

23. PCB layout.



24. Diagram





Modifications and typographical errors reserved
© Velleman Components nv.
H52031P - 2005 - ED1

